

Rivetwise[®]

GRIPCO[®]

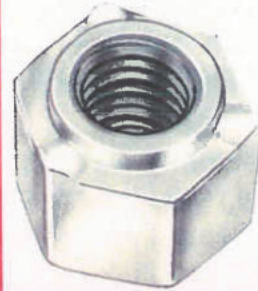

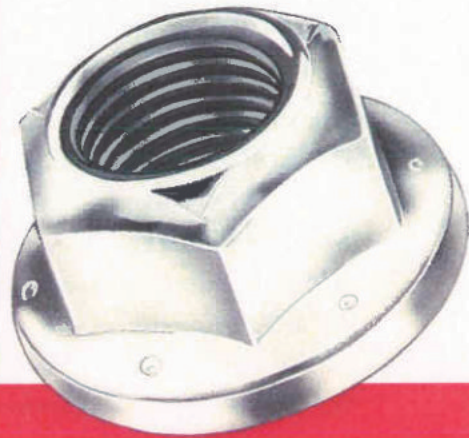
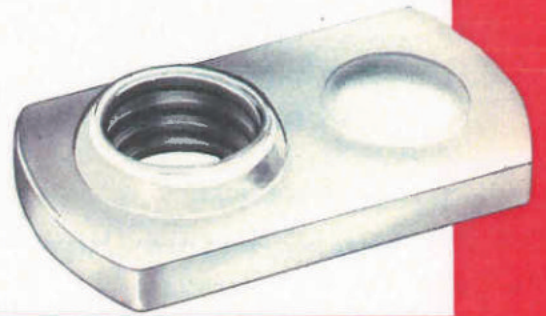
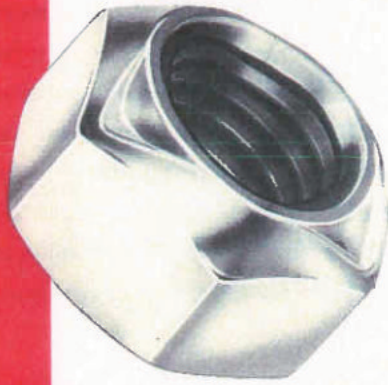
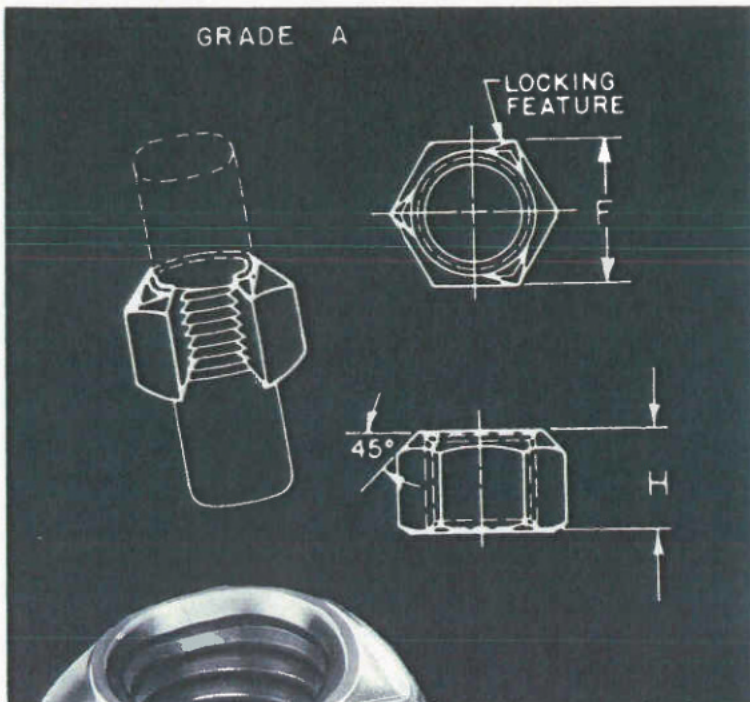

Grade A

CROWNLOCK NUTS

The Gripco Grade A Crownlock Nuts are manufactured from low carbon steel to meet Grade 2 performance specifications. These prevailing torque nuts are designed for use with Grade 2 bolts.

- No markings are required for a Grade A prevailing torque nut.
- Parts are furnished with a cadmium and wax finish or as requested.
- Gripco Crownlock Nuts meet or exceed all current I.F.I. specifications.
- Prices and samples are available upon request.



CROWNLOCK NUTS GRADE A

COARSE		FINE		(F) WIDTH ACROSS FLATS		(H) THICKNESS		CARTON QTY.	WEIGHT PER M
SIZE	PART NO.	SIZE	PART NO.	MAX.	MIN.	MAX.	MIN.		
1/4-20	TLA-1420-S-GRA	1/4-28	TLA-1428-S-GRA	.438	.428	.226	.212	9,000	6.7
5/16-18	TLA-5618-S-GRA	5/16-24	TLA-5624-S-GRA	.500	.489	.273	.258	6,000	10.0
3/8-16	TLA-3816-S-GRA	3/8-24	TLA-3824-S-GRA	.562	.551	.337	.320	4,000	14.7
7/16-14	TLA-7614-S-GRA	7/16-20	TLA-7620-S-GRA	.688	.675	.385	.365	2,000	26.3
1/2-13	TLA-1213-S-GRA	1/2-20	TLA-1220-S-GRA	.750	.736	.448	.427	1,500	34.7
5/8-11	TLA-5811-S-GRA	5/8-18	TLA-5818-S-GRA	.938	.922	.559	.535	800	66.0
3/4-10	TLA-3410-S-GRA	3/4-16	TLA-3416-S-GRA	1.125	1.088	.665	.617	500	115.0
7/8-9	TLA-7809-S-GRA	7/8-14	TLA-7814-S-GRA	1.312	1.269	.776	.724	300	178.0
1"-8	TLA-10008-S-GRA	1"-14	TLA-10014-S-GRA	1.500	1.450	.887	.831	200	268.0
1 1/8-7	TLA-11807-S-GRA	1 1/8-12	TLA-11812-S-GRA	1.688	1.631	.999	.939	120	386.0
1 1/4-7	TLA-11407-S-GRA	1 1/4-12	TLA-11412-S-GRA	1.875	1.812	1.094	1.031	90	500.0
1 1/2-6	TLA-11206-S-GRA	1 1/2-12	TLA-11212-S-GRA	2.250	2.175	1.317	1.245	50	863.0

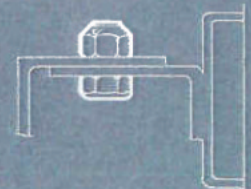
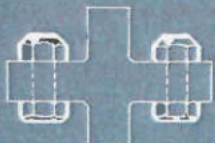

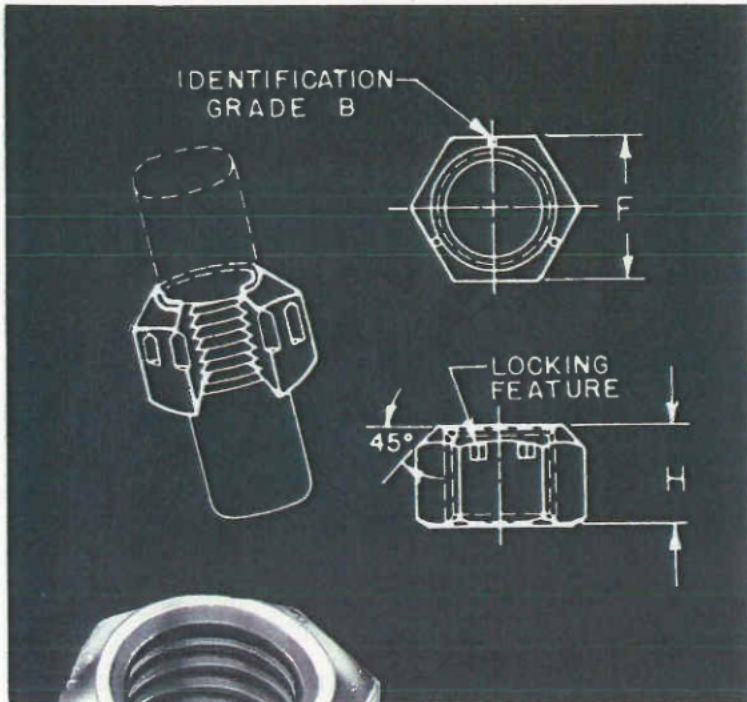

Grade B

CROWNLOCK NUTS

The Gripco Grade B Crownlock Nuts are manufactured from low carbon steel and processed to meet Grade 5 performance specifications. These prevailing torque nuts are designed for use with Grade 5 bolts.

- Three dots at 120° intervals on the crown of the nut identify this product as a Grade B prevailing torque nut.
- Parts are furnished with a cadmium and wax finish or as requested.
- Gripco Crownlock Nuts meet or exceed all current I.F.I. specifications.
- Prices and samples are available upon request.



CROWNLOCK NUTS GRADE B

SIZE	COARSE PART NO.	SIZE	FINE PART NO.	(F) WIDTH ACROSS FLATS		(H) THICKNESS		CARTON QTY.	WEIGHT PER M
				MAX.	MIN.	MAX.	MIN.		
8-32	**TLA-0832-S-GRB			.344	.332	.195	.179	19,000	3.4
10-24	**TLA-1024-S-GRB	10-32	**TLA-1032-S-GRB	.375	.362	.211	.195	15,00	4.3
1/4-20	WLA-1420-S-GRB	1/4-28	WLA-1428-S-GRB	.438	.428	.257	.243	8,500	7.8
5/16-18	WLA-5618-S-GRB	5/16-24	WLA-5624-S-GRB	.500	.489	.302	.292	5,500	11.2
3/8-16	WLA-3816-S-GRB	3/8-24	WLA-3824-S-GRB	.562	.551	.377	.360	3,500	16.0
7/16-14	WLA-7614-S-GRB	7/16-20	WLA-7620-S-GRB	.688	.675	.430	.410	2,000	29.8
1/2-13	WLA-1213-S-GRB	1/2-20	WLA-1220-S-GRB	.750	.736	.510	.490	1,500	39.4
5/8-11	WLA-5811-S-GRB	5/8-18	WLA-5818-S-GRB	.938	.922	.645	.621	700	78.9
3/4-10	WLA-3410-S-GRB	3/4-16	WLA-3416-S-GRB	1.125	1.088	.750	.702	450	126.0

NOTE: 7/8"-NC & NF and 1" NC & NF Available

**These sizes will have same type locking feature as Crownlock Nuts A and C.

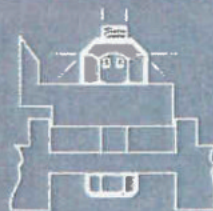
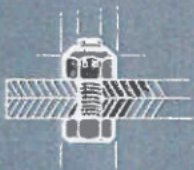

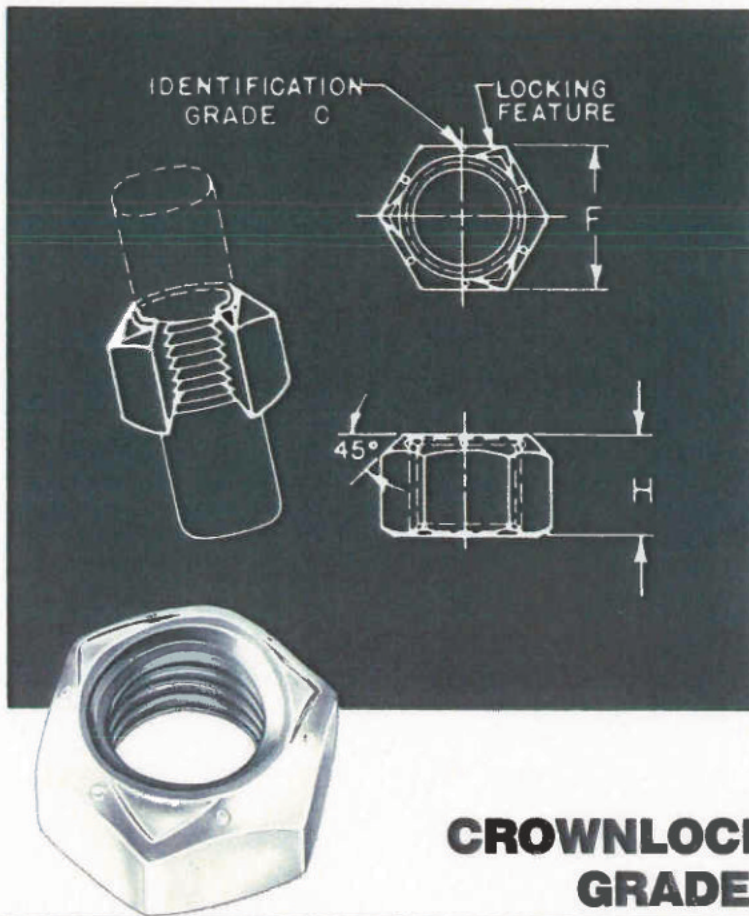

Grade C

CROWNLOCK NUTS

The Gripco Grade C Crownlock Nuts are manufactured from medium carbon steel and heat treated to meet Grade 8 performance specifications. These prevailing torque nuts are designed for high strength applications for use with Grade 8 bolts.

- Six dots at 60° intervals on the crown of the nut identify this product as a Grade C prevailing torque nut.
- Parts are furnished with a cadmium and wax finish or as requested.
- Gripco Crownlock Nuts meet or exceed all current I.F.I. specifications.
- Prices and samples are available upon request.

CROWNLOCK NUTS GRADE C

SIZE	COARSE PART NO.	SIZE	FINE PART NO.	(F) WIDTH ACROSS FLATS		(H) THICKNESS		CARTON QTY.	WEIGHT PER M
				MAX.	MIN.	MAX.	MIN.		
1/4-20	TLA-1420-S-GRC	1/4-28	TLA-1428-S-GRC	.438	.428	.226	.212	9,000	6.7
5/16-18	TLA-5618-S-GRC	5/16-24	TLA-5624-S-GRC	.500	.489	.273	.258	6,000	10.0
3/8-16	TLA-3816-S-GRC	3/8-24	TLA-3824-S-GRC	.562	.551	.337	.320	4,000	14.7
7/16-14	TLA-7614-S-GRC	7/16-20	TLA-7620-S-GRC	.688	.675	.385	.365	2,000	26.3
1/2-13	TLA-1213-S-GRC	1/2-20	TLA-1220-S-GRC	.750	.736	.448	.427	1,500	34.7
9/16-12	TLA-9612-S-GRC	9/16-18	TLA-9618-S-GRC	.875	.861	.496	.473	1,000	53.7
5/8-11	TLA-5811-S-GRC	5/8-18	TLA-5818-S-GRC	.938	.922	.559	.535	800	66.0
3/4-10	TLA-3410-S-GRC	3/4-16	TLA-3416-S-GRC	1.125	1.088	.665	.617	500	115.0
7/8-9	TLA-7809-S-GRC	7/8-14	TLA-7814-S-GRC	1.312	1.269	.776	.724	300	178.0
1"-8	TLA-10008-S-GRC	1"-14	TLA-10014-S-GRC	1.500	1.450	.887	.831	200	268.0
1 1/8-7	TLA-11807-S-GRC	1 1/8-12	TLA-11812-S-GRC	1.688	1.631	.999	.939	120	377.9
1 1/4-7	TLA-11407-S-GRC	1 1/4-12	TLA-11412-S-GRC	1.875	1.812	1.094	1.030	90	500.0
1 1/2-6	TLA-11206-S-GRC	1 1/2-12	TLA-11212-S-GRC	2.250	2.175	1.317	1.245	50	863.0

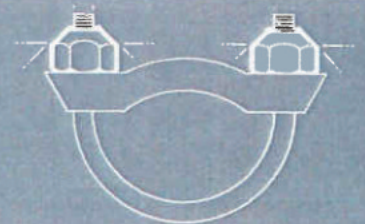
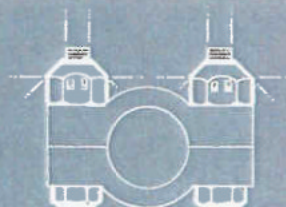
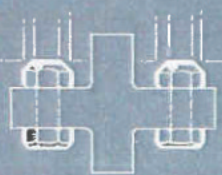

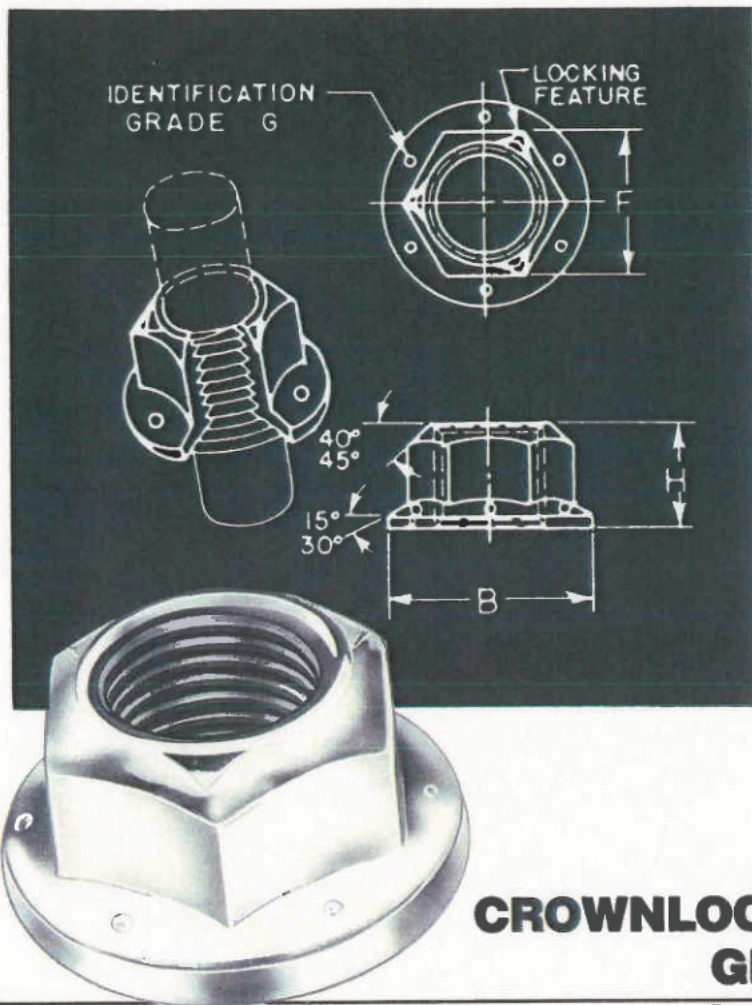

Grade G CROWNLOCK FLANGE NUTS

The Gripco Grade G Crownlock Flange Nuts are manufactured from medium carbon steel and heat treated to meet Grade G performance specifications. Greater height and the added hoop strength of the flange provide 30% more strength than a standard nut. These prevailing torque nuts are designed for high strength applications for use with Grade 8 bolts.

Six dots at 60° intervals on the top of the flange identify this product as a Grade G prevailing torque flange nut.

- Parts are furnished with a cadmium and wax finish or as requested.
- Gripco Crownlock Flange Nuts meet or exceed all current I.F.I. specifications.
- Prices and samples are available upon request.

CROWNLOCK FLANGE NUTS GRADE G

SIZE	COARSE PART NO.	SIZE	FINE PART NO.	(F) WIDTH ACROSS FLATS		(H) THICKNESS		(B) FLANGE DIAMETER		CARTON QTY.	WEIGHT PER M
				MAX.	MIN.	MAX.	MIN.	MAX.	MIN.		
¼-20	TLGF-1420-S	¼-28	TLGF-1428-S	.4385	.428	.291	.251	.560	.522	6,000	9.6
⅝-18	TLGF-5618-S	⅝-24	TLGF-5624-S	.502	.489	.354	.303	.680	.642	4,400	14.8
⅜-16	TLGF-3816-S	⅜-24	TLGF-3824-S	.5645	.551	.421	.357	.810	.770	2,000	25.0
7/16-14	TLGF-7614-S	7/16-20	TLGF-7620-S	.6895	.675	.482	.414	.930	.888	1,500	38.7
½-13	TLGF-1213-S	½-20	TLGF-1220-S	.752	.736	.550	.469	1.070	1.026	1,000	54.7
9/16-12	TLGF-9612-S	9/16-18	TLGF-9618-S	.877	.861	.611	.527	1.190	1.146		
5/8-11	TLGF-5811-S	5/8-18	TLGF-5818-S	.9395	.922	.678	.581	1.330	1.280	500	107.0
¾-10	TLGF-3410-S	¾-16	TLGF-3416-S	1.127	1.088	.802	.682	1.585	1.529	325	166.6
7/8-9	TLGF-7809-S	7/8-14	TLGF-7814-S	1.3145	1.269	.928	.794	1.840	1.778	200	270.5
1"-8	TLGF-10008-S	1"-14	TLGF-10014-S	1.502	1.450	1.047	.897	2.106	2.038		

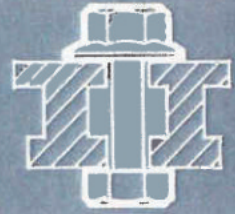
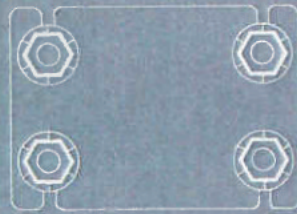

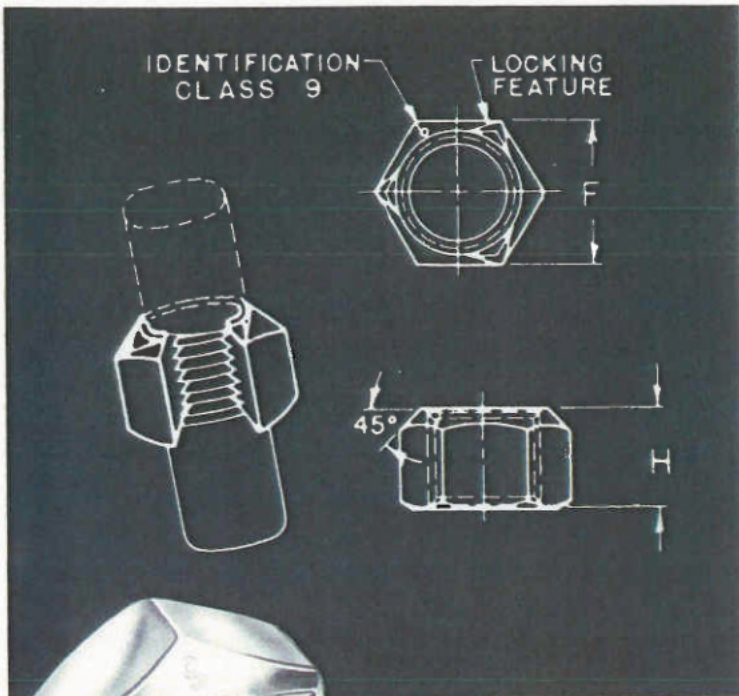

Class 9 METRIC CROWNLOCK NUTS

The Gripco Class 9 Metric Crownlock Nuts are manufactured from low carbon steel to meet Class 9 performance specifications. These prevailing torque nuts are designed for use with Class 9.8 bolts.

- The numeral 9 on the crown of the nut identifies this part as a Class 9 nut.
- Parts are furnished with a cadmium and wax finish or as requested.
- Gripco Metric Crownlock Nuts meet or exceed all current A.N.S.I. specifications.
- Prices and samples are available upon request.

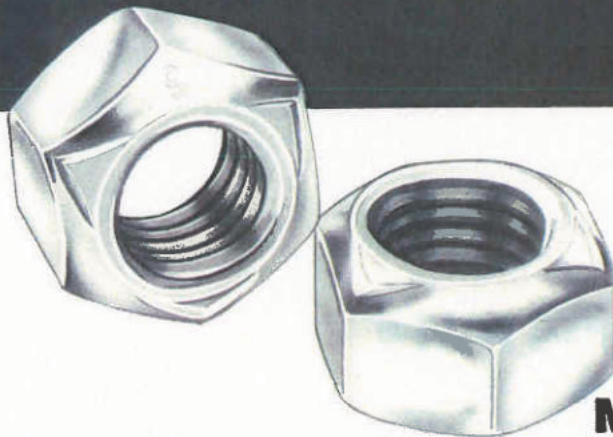

METRIC CROWNLOCK NUTS CLASS 9

PART NO./SIZE	WIDTH ACROSS FLATS		THICKNESS		CARTON QTY.	WEIGHT PER M
	MAX. (F)	MIN.	MAX. (H)	MIN.		
TLA9-M6x1	10.05	9.76	6.7	6.2		
TLA9-M8x1.25	13.05	12.73	8.0	7.4	5,000	11.9
TLA9-M10x1.5	15.05	14.70	11.2	10.2		
TLA9-M12x1.75	18.05	17.67	13.3	12.3	1,500	36.4
TLA9-M14x2	21.05	20.64	15.4	14.3		
TLA9-M16x2	24.05	23.61	17.9	16.8		
TLA9-M20x2.5	30.05	29.00	21.8	20.2		
TLA9-M24x3	36.05	34.80	26.4	24.3		

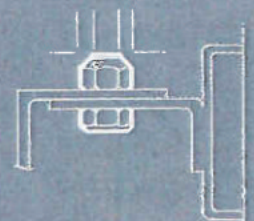
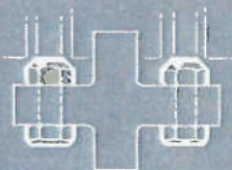

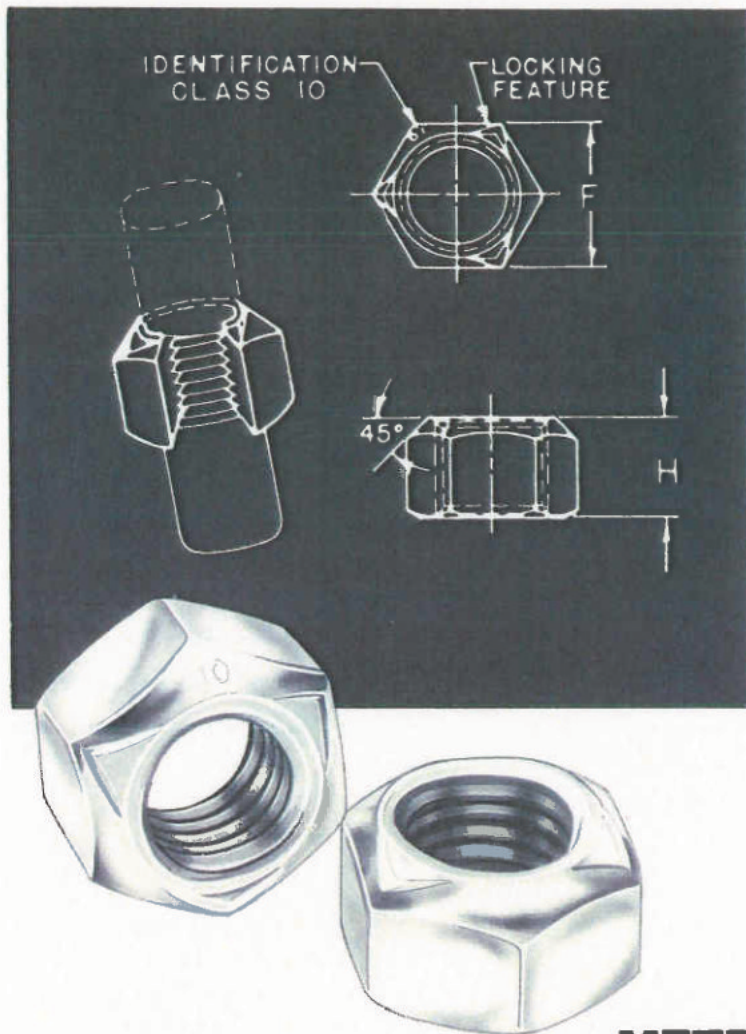

Class 10

METRIC CROWNLOCK NUTS

The Gripco Class 10 Metric Crownlock Nuts are manufactured from medium carbon steel and heat treated to meet Class 10 performance specifications. These prevailing torque nuts are designed for use with Class 10.9 bolts.

- The numeral 10 on the crown of the nut identifies this part as a Class 10 nut.
- Parts are furnished with a cadmium and wax finish or as requested.
- Gripco Metric Crownlock Nuts meet or exceed all current A.N.S.I. specifications.
- Prices and samples are available upon request.

METRIC CROWNLOCK NUTS CLASS 10

PART NO./SIZE	WIDTH ACROSS FLATS			THICKNESS		CARTON QTY.	WEIGHT PER M	
	MAX.	(F)	MIN.	MAX.	(H)			MIN.
TLA10-M6x1	10.05		9.76	5.75		5.4	10,000	5.5
TLA10-M8x1.25	13.05		12.73	6.9		6.5	5,500	11.2
TLA10-M10x1.5	15.05		14.70	9.05		8.6	3,000	17.2
TLA10-M12x1.75	18.05		17.67	11.1		10.6	1,800	31.6
TLA10-M14x2	21.05		20.64	12.45		11.9	1,200	47.5
TLA10-M16x2	24.05		23.61	14.5		13.9	850	73.8
TLA10-M20x2.5	30.05		29.00	18.1		17.4	400	136.0

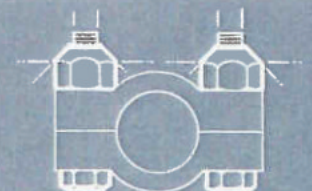
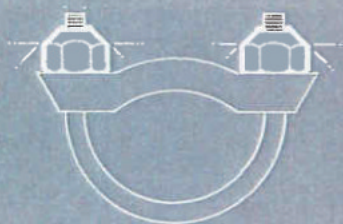
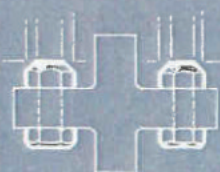

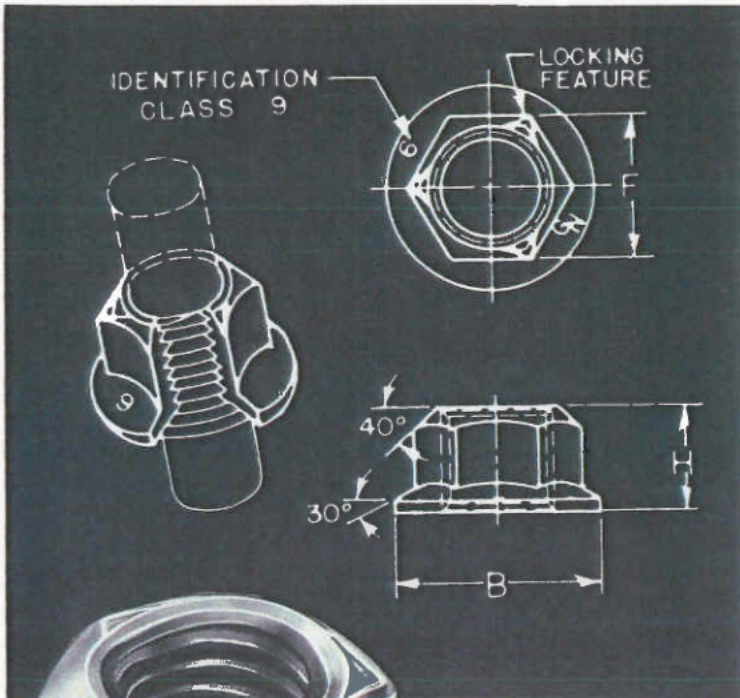

Class 9 METRIC CROWNLOCK FLANGE NUTS

The Gripco Metric Crownlock Flange Nuts are manufactured from low carbon steel to meet Class 9 performance specifications. Greater height and the added hoop strength of the flange provide 30% more strength than a standard nut. These prevailing torque nuts are designed for use with Class 9.8 bolts.

- The numeral 9 on the top of the flange identifies this part as a Class 9 flange nut.
- Parts are furnished with a cadmium and wax finish or as requested.
- Gripco Metric Crownlock Flange Nuts meet or exceed all current A.N.S.I. specifications.
- Prices and samples are available upon request.

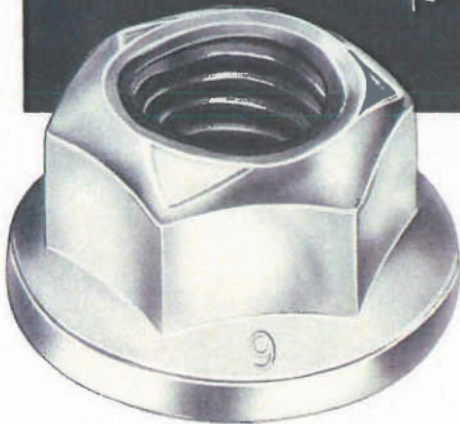

METRIC CROWNLOCK FLANGE NUTS CLASS 9

PART NO./SIZE	WIDTH ACROSS FLATS		THICKNESS		FLANGE DIAMETER		CARTON QTY.	WEIGHT PER M
	MAX.	(F) MIN.	MAX.	(H) MIN.	MAX.	(B) MIN.		
TLF9-M6x1	10.00	9.76	7.70	7.35	14.2	13.2	7,000	8.8
TLF9-M8x1.25	13.00	12.73	9.40	9.00	17.6	16.9	3,500	18.0
TLF9-M10x1.5	15.00	14.70	12.25	11.75	21.5	20.8	1,700	30.0
TLF9-M12x1.75	18.00	17.67	13.00	12.4	25.6	24.9		
TLF9-M14x2	21.00	20.64	17.05	16.50	29.6	28.4	650	89.6

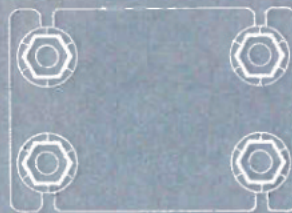

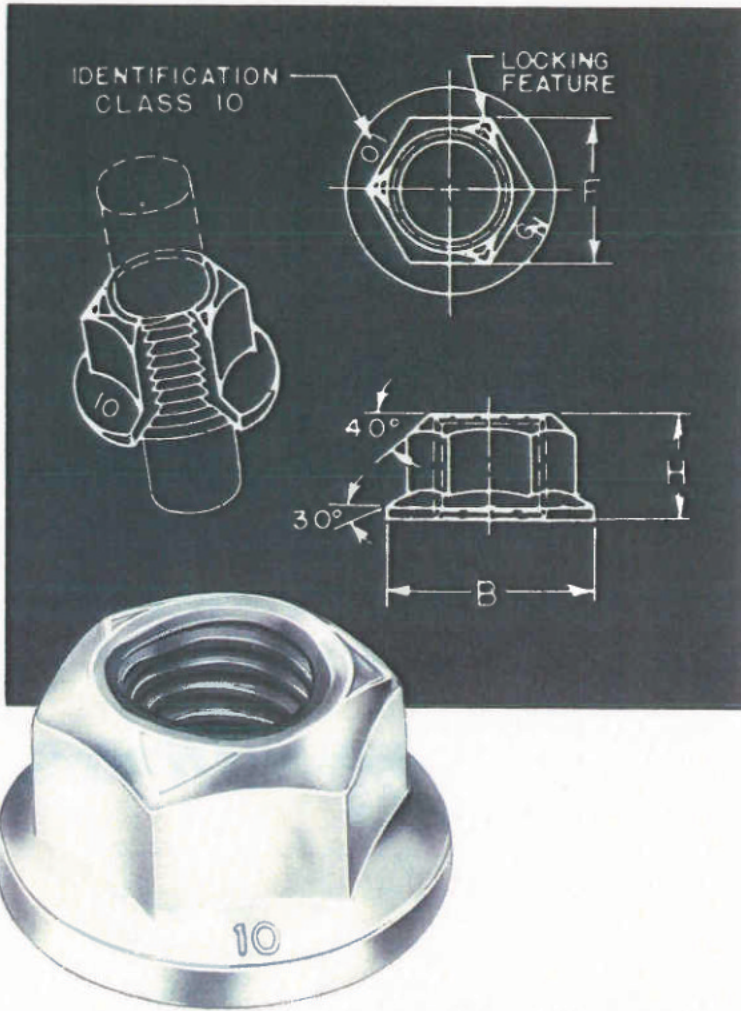

Class 10

METRIC CROWNLOCK FLANGE NUTS

The Gripco Metric Crownlock Flange Nuts are manufactured from medium carbon steel and heat treated to meet Class 10 performance specifications. Greater height and the added hoop strength of the flange provide 30% more strength than a standard nut. These prevailing torque nuts are designed for high strength applications for use with Class 10.9 bolts.

- The numeral 10 on the top of the flange identifies this part as a Class 10 flange nut.
- Parts are furnished with a cadmium and wax finish or as requested.
- Gripco Metric Crownlock Flange Nuts meet or exceed all current A.N.S.I. specifications.
- Prices and samples are available upon request.

CROWNLOCK FLANGE NUTS CLASS 10

PART NO./SIZE	WIDTH ACROSS FLATS		THICKNESS		FLANGE DIAMETER		CARTON QTY.	WEIGHT PER M
	MAX.	(F) MIN.	MAX.	(H) MIN.	MAX.	(B) MIN.		
TLF10-M6x1	10.05	9.76	7.4	6.4	14.2	13.2	8,000	7.7
TLF10-M8x1.25	13.05	12.73	9.1	8.1	17.6	16.8	3,500	16.4
TLF10-M10x1.5	15.05	14.70	11.7	10.7	21.5	20.4	2,000	29.0
TLF10-M12x1.75	18.05	17.67	14.0	12.8	25.6	24.5	1,000	52.7
TLF10-M14x2	21.05	20.64	15.9	14.6	29.6	28.5	650	79.7
TLF10-M16x2	24.05	23.61	18.9	17.6	34.2	32.9	450	122.0
TLF10-M20x2.5	30.05	29.00	23.9	22.4	42.3	40.8	200	213.2

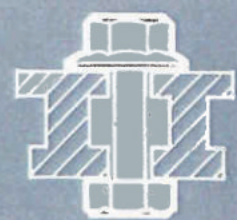
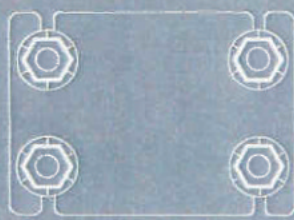

WARRANTY POLICY

In cases where Gripco products are either heat treated, welded or given a protective coating following delivery to the purchaser, the Gripco Fastener Division shall not be held responsible for failures of the product to meet dimensional, mechanical or performance requirements.

RETURNED GOODS POLICY

The return of goods by customers will not be allowed without prior written authorization. Please contact the South Whitley sales office with any request for the return of material.

QUALITY ASSURANCE POLICY

Unless otherwise specified by the customer at the time of the inquiry (verbal or written) or on the purchase order, parts will be processed in accordance with standard in-house procedures. Certifications require prior notification. Please contact Gripco, South Whitley sales office for additional information on your requirements.

COUNTRY OF ORIGIN

All finished products illustrated in this catalog are manufactured in the United States of America. Manufacturing facilities are located at South Whitley, Indiana and Montpelier, Indiana.

GRIPCO®

**Emhart Fastening Technologies
Industrial Division**

**510 River Road
Shelton, CT 06484
Tel. (203) 944-1711
Fax (800) 220-4286**

Canadian Office

**3545 Thimens Boulevard
St. Laurent, Quebec, H4R 1V5
Tel. (514) 333-8080
Fax (514) 338-3829**

**Emhart
GRIPCO**

A  **BLACK & DECKER** COMPANY